

Genius XE QSD

High performance nitrogen & air generator for PerkinElmer QSight Dual Source LC-MS

Part Number : 3303146

Service Kit : See reverse



Your local **gas generation** partner

Description

Combining advanced technology with refined and robust engineering, Genius XE QSD provides a premium standalone nitrogen solution custom designed to meet the requirements of PerkinElmer QSight Dual Source LC-MS.

Featuring dual outlets (1 x nitrogen, 1 x air), the generator is precision engineered to reduce size as well as noise and heat emissions. Genius XE QSD has been tested and validated by PerkinElmer for use with their QSight Dual Source LC-MS and comes with factory pre-set pressures and flows to meet the exact demands of the system.

Applications

- Dual and single source PerkinElmer QSight 100, 200 and 400 Series

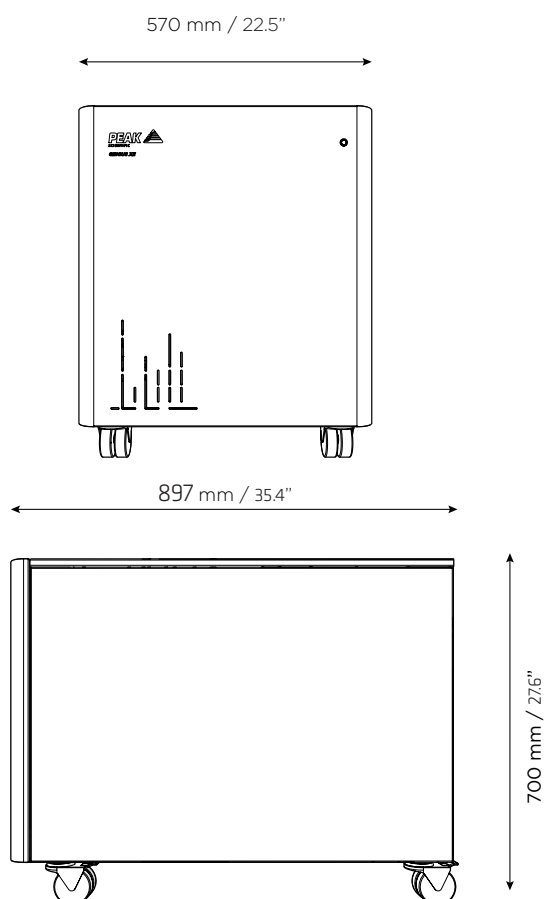

Key Features

- Factory pre-set pressures and flows to meet exact demands of PE QSight Dual Source Systems
- Multi- Stage Drying Filtration to efficiently remove moisture and contaminants, providing a consistent quality of gas
- Low impact on lab environment with low noise and heat emissions
- Next-generation high performance premium compressors, engineered exclusively for Genius XE
- Intuitive LED Service Indication
- ECO (Electronic Compressor Optimisation™) technology for low energy consumption and compressor durability
- Fixed annual maintenance schedule
- 1 year comprehensive manufacturer's warranty

Technical Specifications	Genius XE QSD
Nitrogen Maximum Flow	16L/min @ 5.52bar (0.57cfm @ 80psi)
Air Maximum Flow	67L/min @ 7.58bar (2.37cfm @ 110psi)
Dewpoint	Nitrogen ≤ -40°C Dry Air ≤ -20°C
Gas Outlets	2 x 1/4" BSPP
Drain Outlet	1 x 1/4" BSPP
Particles	<0.01µm
Phthalates	None
Suspended Liquids	None
Operating Temperature	15°C (59°F) to 30°C (86°F)
Electrical Requirements	220 - 240v ±10% 50/60 Hz
Power Consumption	1.64 kVA
Heat Output	<5545 BTU
Noise Level	57dB(A) @ 1m
Generator Dimensions (H x W x D)	700 x 570 x 897 mm 27.6 x 22.5 x 35.4"
Generator Weight	153KG

Ordering Information	
Part Number	3303146
Annual Service	visit: www.peakscientific.com/ordering
Complete Maintenance Plan	

[PEAK Protected]™

Peak Scientific gas generators define the benchmark in reliability, convenience and performance in laboratories around the world, and come backed by a 12 month warranty. Beyond this period however you can ensure that your investment continues to be **[Protected]** by our comprehensive generator care cover.

Our world-class aftercare support packages deliver a program of scheduled preventative maintenance whilst giving you the reassurance of instant access to worldwide technical support and priority on-site response in the untimely event of a breakdown.

Peak Scientific UK
Tel: +44 (0)141 812 8100
Fax: +44 (0)141 812 8200

Peak Scientific North America
Tel: +1 866 647 1649
Fax: +1 978 608 9503

For a full list of our worldwide office locations, please visit:
www.peakscientific.com/offices

Web: www.peakscientific.com
Email: discover@peakscientific.com

Peak Scientific's Quality Management System conforms to:
ISO 9001:2015



Product Certifications

