

Halo

Nitrogen generator for MP-AES

Description

Designed as a dedicated solution for MP-AES instruments supplying the high purity nitrogen for plasma support gas and monochromator purge and air supply for POP gas or monochromator air purge, Halo produces 25 LPM of 99.5% or 10LPM of 99.95% pure nitrogen with a supporting air supply of up to 36.5 LPM. Fitted with an oxygen analyzer, Halo will alert when operating purity has been reached through a purity status indicating LED light.

Compact in size, Halo is a space-saving solution for the lab, freeing up valuable lab space whilst being far easier to transport for field research than bulky gas cylinders. Manufactured by Peak's laboratory gas generation experts, Halo has been engineered to operate comfortably at high altitude with the most advanced gas generation technology to produce the reliable, high purity nitrogen for your MP-AES application.

Applications

On-demand nitrogen and air source for:

- ▶ MP-AES*



Key Features

- ▶ Nitrogen at 25 LPM at 99.5% purity or 10 LPM at 99.95%
- ▶ Air supply at 36.5 LPM at -20°C ADP
- ▶ O₂ analyzer with LED light to indicate when operating purity is reached
- ▶ Compact, mobile, space-saving solution
- ▶ Latest generation, high specification compressor located in insulated chamber to minimize noise and vibration
- ▶ Capable at operating in high altitude environments (up to 4,000m) without performance loss
- ▶ Less than 30 minutes start-up to operating purity
- ▶ Remove the hassle and safety concerns of ordering, transporting and changing out pressurized cylinders
- ▶ Manufactured and tested in U.K. to highest spec., CE/ FCC certified
- ▶ 12 month fully comprehensive manufacturer's warranty inclusive

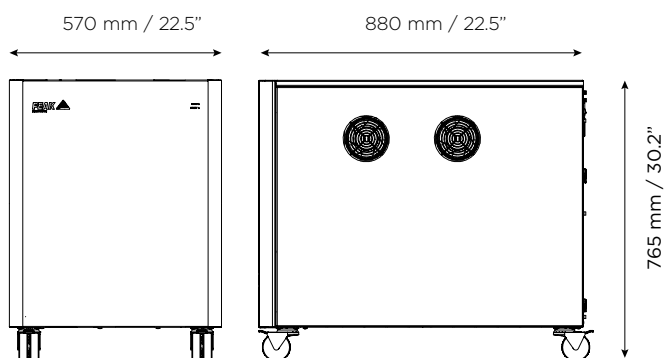

* For the additional gas requirements of Sulphur Determination using MP-AES, we recommend Halo & Genius 1053

Technical Specifications

	HALO	
	Nitrogen	Air
Max Flow Rate	up to 25 L/min	up to 36.5 L/min
Max Pressure	87 psi (6 bar)	87 psi (6 bar)
Purity	> 99.5 % (99.95% @ 10L/min)	-
Dew Point	-	-20 °C / -4 °F
Gas Outlets	2 x 1/4" BSPP	
Max Relative Humidity	80% RH @ 31°C	
Max Altitude	4000m	
Particles	< 0.01 µm	
Suspended Liquids	None	
Operating Temperature	5°C (41°F) to 35°C (95°F)*	
Electrical Requirements	230VAC 50/60Hz, 10A	
Power Consumption	2200 VA	
Heat Output	7506 BTU	
Generator Dimensions (H x W x D)	765 x 570 x 880 mm 30.2 x 22.5 x 36.7"	
Generator Weight	155 kg / 341.8 lbs	

Ordering Information

Part Number	3300825
Annual Service	visit: www.peakscientific.com/ordering
Complete Maintenance Plan	

*Operating at an altitude between 3000m - 4000m max operating temperature is 25°C (77°F)

[PEAK Protected]™

Peak Scientific gas generators define the benchmark in reliability, convenience and performance in laboratories around the world, and come backed by a 12 month warranty. Beyond this period however you can ensure that your investment continues to be **[Protected]** by our comprehensive generator care cover.

Our world-class aftercare support packages deliver a program of scheduled preventative maintenance whilst giving you the reassurance of instant access to worldwide technical support and priority on-site response in the untimely event of a breakdown.

Peak Scientific UK
Tel: +44 (0)141 812 8100
Fax: +44 (0)141 812 8200

Peak Scientific North America
Tel: +1 866 647 1649
Fax: +1 978 608 9503

For a full list of our worldwide office locations, please visit: www.peakscientific.com/offices

Web: www.peakscientific.com
Email: discover@peakscientific.com

Peak Scientific's Quality Management System conforms to:
ISO 9001:2015



Product Certifications

