

# ONEFIVE AEROPULSE FS50

High power femtosecond fiber laser



## HIGH PERFORMANCE AND RUGGED ULTRAFAST FIBER LASER

### Industrial-grade femtosecond fiber laser

The aeroPULSE FS50 is our new industrial-grade femtosecond fiber laser based on our world-leading photonic crystal fiber platform.

Developed for both demanding 24/7 OEM and academic applications, the aeroPULSE FS50 delivers high unit-to-unit consistency and up-time, low cost of ownership, and ease of integration.

### Applications

- Thin film cutting
- Glass cutting
- Stent manufacture
- Medical device fabrication
- IC package cutting
- Scribing
- OPA Pumping
- Femtosecond materials processing

# ONEFIVE AEROPULSE FS50

## Ultra-short femtosecond pulses

This high performance and rugged OEM fiber laser utilize state-of-the-art mode-locking technology to deliver ultra-short femtosecond pulses with outstanding long-term stability, superior pulse-to-pulse stability, low noise, and excellent beam pointing stability.

## Developed for cutting edge applications

The aeroPULSE FS50 is designed for a diverse range of applications including thin film cutting, glass cutting, stent, and other medical devices, IC package cutting, scribing, OPA pumping and material processing.

With the introduction of programmable amplifier burst control, higher ablation rates or depths can be achieved over non-burst processing for many applications. This new feature allows for full process optimization.

As standard, the aeroPULSE FS50 is available with output powers up to 50 W at 1030 nm. With tunable pulse duration and a high range of repetition rates, the aeroPULSE FS50 is a flexible, cost-effective femtosecond laser.

## Get the dual wavelength second-harmonic module

The attachable second-harmonic generation (SHG) module makes it possible to switch between 20  $\mu$ J at 515 nm and 40  $\mu$ J at 1030 nm. The wavelength is selected via software.

## Maintenance-free and OEM-ready

Utilising NKT Photonics proprietary optoCAGE™ technology results in no alignment for ultimate reliability. The aeroPULSE FS50 guarantees high stability with 24/7 operation and is ideal for OEM integration.

The system configuration consists of a 19" rack-mountable control unit and a remote laser head. The complete system is water-cooled supporting the high output power performance.

## Features

- Average power >50W @1030nm
- Average pulse energy >40 $\mu$ J @1030nm
- Average power 25W @515nm w/SHG
- Average pulse energy >20 $\mu$ J @515nm w/SHG
- Available pulse widths <500 - 3 ps
- Up to 50 MHz repetition rate
- Excellent beam pointing stability
- Programmable amplifier burst control
- Based on world leading photonic crystal fiber technology
- Designed for industrial reliability
- System monitoring via remote diagnostics
- Plug and Play
- Maintenance-free 24/7 operation
- Attachable second harmonic module

## Support and warranty

The product is covered by a comprehensive warranty. Service options are available. For details, please enquire.

All aeroPULSE lasers are completely maintenance-free and have an expected lifetime of more than 20,000 hours.

# PERFORMANCE

## Typical output power vs repetition rate

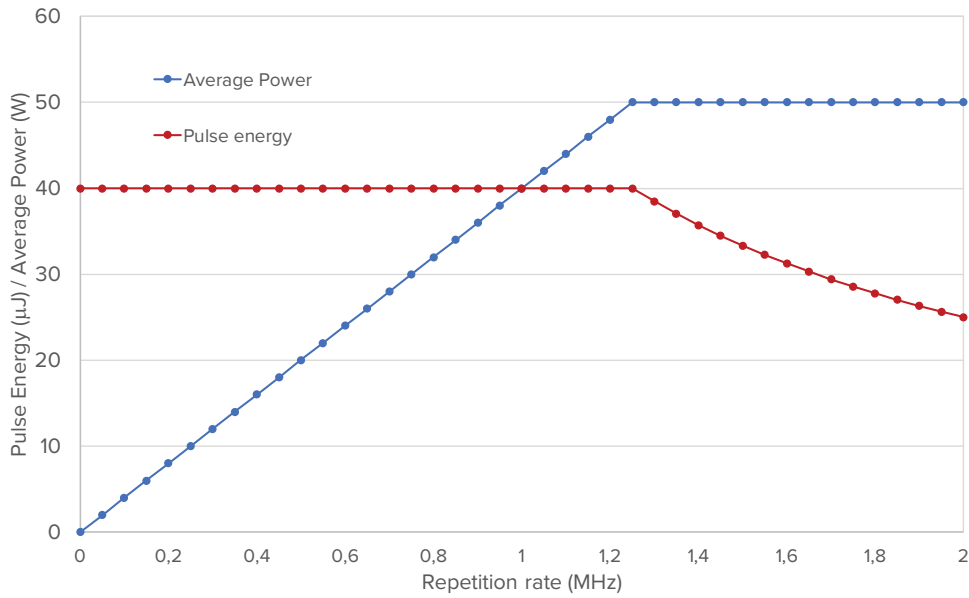

# SPECIFICATIONS

## Optical

Model	FS50	With dual wavelength module
		FS50-05
Center wavelength [nm]	1030 ± 5	515 ± 2
Power [W]	> 50	> 25
Pulse duration [fs]	< 500 – 3000	< 500
Pulse energy [μJ]	> 40 (up to 1.25 MHz)	> 20 (up to 1.25 MHz)
Repetition rate [MHz] <sup>1)</sup>	1 – 2	1 – 2
Repetition rate with output AOM [MHz]	S.S. – 1.5	S.S. – 1.5
Beam diameter [mm]	2.5 ± 0.5	2.0 ± 0.5
Spatial mode, fundamental	M <sup>2</sup> ≤ 1.3	M <sup>2</sup> ≤ 1.3
Beam asymmetry/ellipticity [%]	< 15	< 20
Power stability (8h), RMS [%]	< 0.5	< 0.5
Pointing stability (8 hours) [μrad]	< 50	< 50
Polarization - linear, PER [dB]	> 20	> 20

1) High repetition rates available upon request.

## Mechanical/Electrical

Model	FS50	With dual wavelength module
		FS50-05
Computer interface	USB 2.0, RS-232, Ethernet	USB 2.0, RS-232, Ethernet
Operating voltage	100-240 VAC, 50-60 Hz	100-240 VAC, 50-60 Hz
Power consumption [W]	< 600	< 600
Operation temperature [°C]	15 – 35	15 – 35
Storage temperature [°C]	-20 – 60	-20 – 60
Laser head dimensions (LxHxW) [mm <sup>3</sup> ]	647.5 x 142 x 350	809.5 x 142 x 350
Laser head weight [kg]	35	39
Control unit dimensions (LxHxW) [mm <sup>3</sup> ]	442 x 168.5 x 374	442 x 168.5 x 374
Control unit weight [kg]	18.5	18.5
Umbilical length [m]	4	4
Chiller dimensions (WxHxL) [mm <sup>3</sup> ]	482 x 310 x 550	482 x 310 x 550
Chillerweight [kg]	40	40
Cooling	Water-based	Water-based

# TECHNICAL DRAWINGS

## Laser head

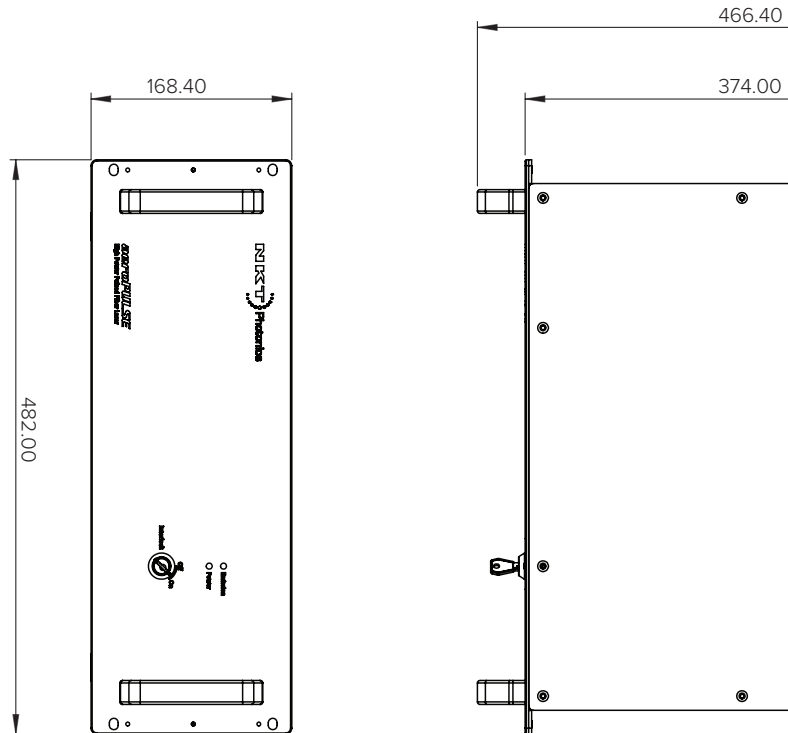

## Laser head with SHG module

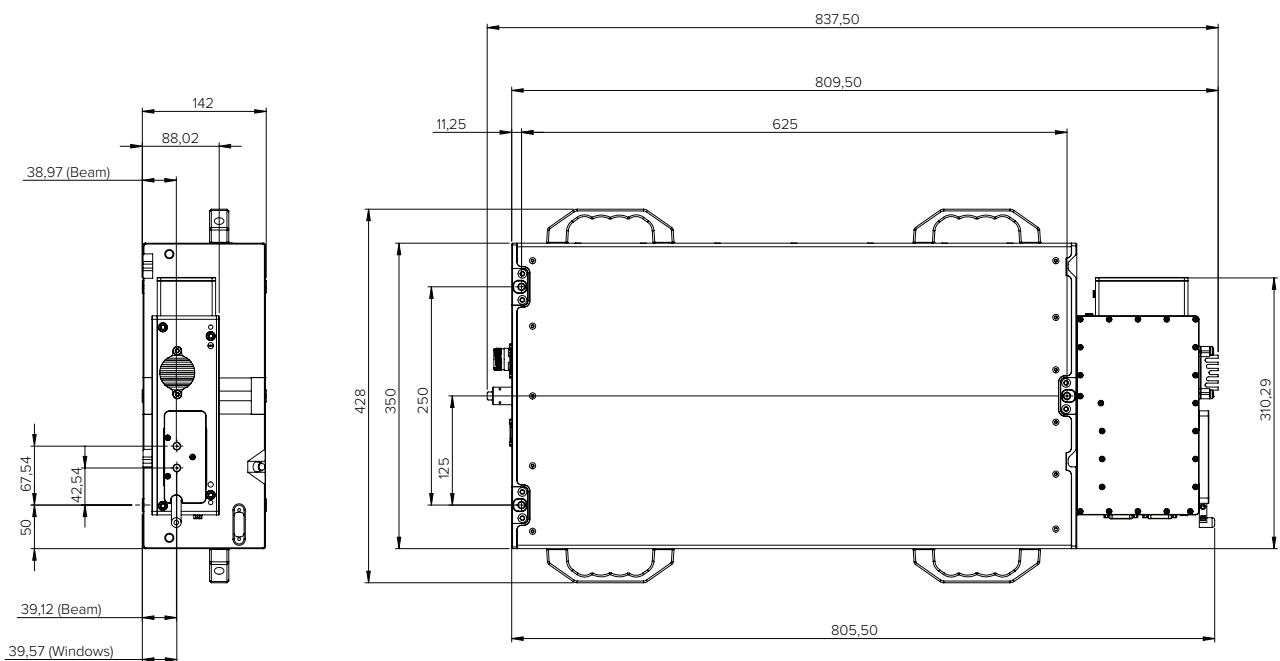

# TECHNICAL DRAWINGS

## Controller

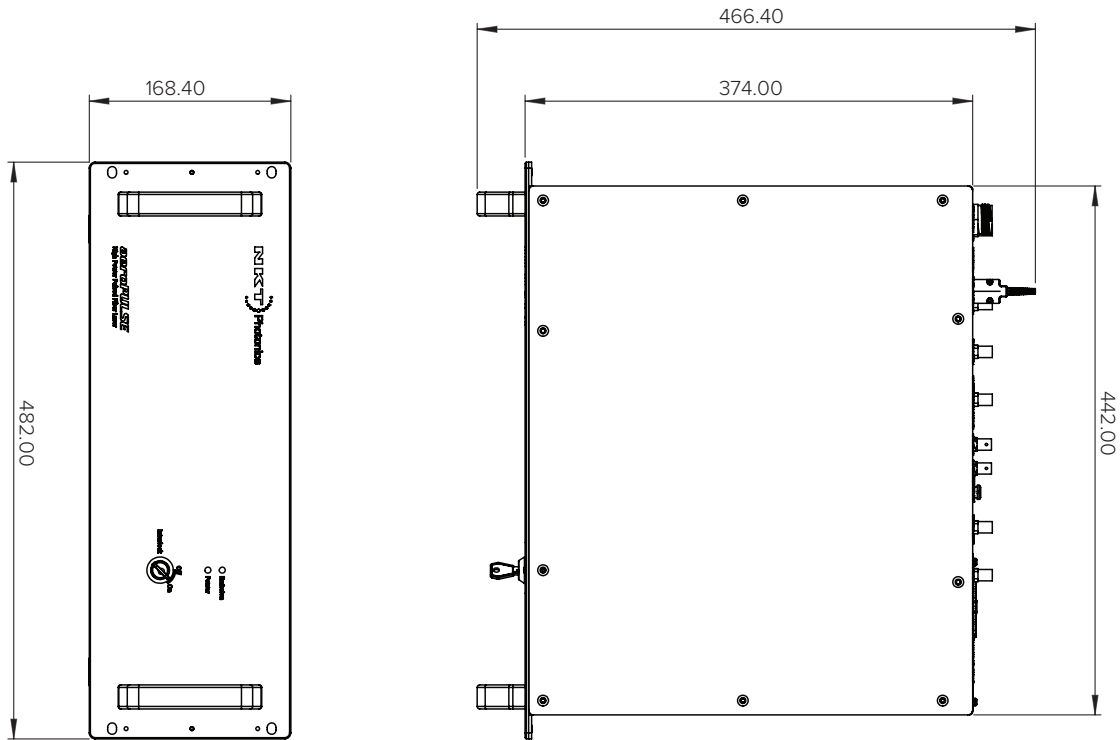

All aeroPULSE FS50 products are produced under our quality management system certified in accordance with the ISO 9001:2015.

